

# Recommended Driven Cleaning and Maintenance

*Driven Clutch not working as well as it should?  
Here are some great tips to help you keep the JR Race Car  
quality your Driven clutch had when it was new.*

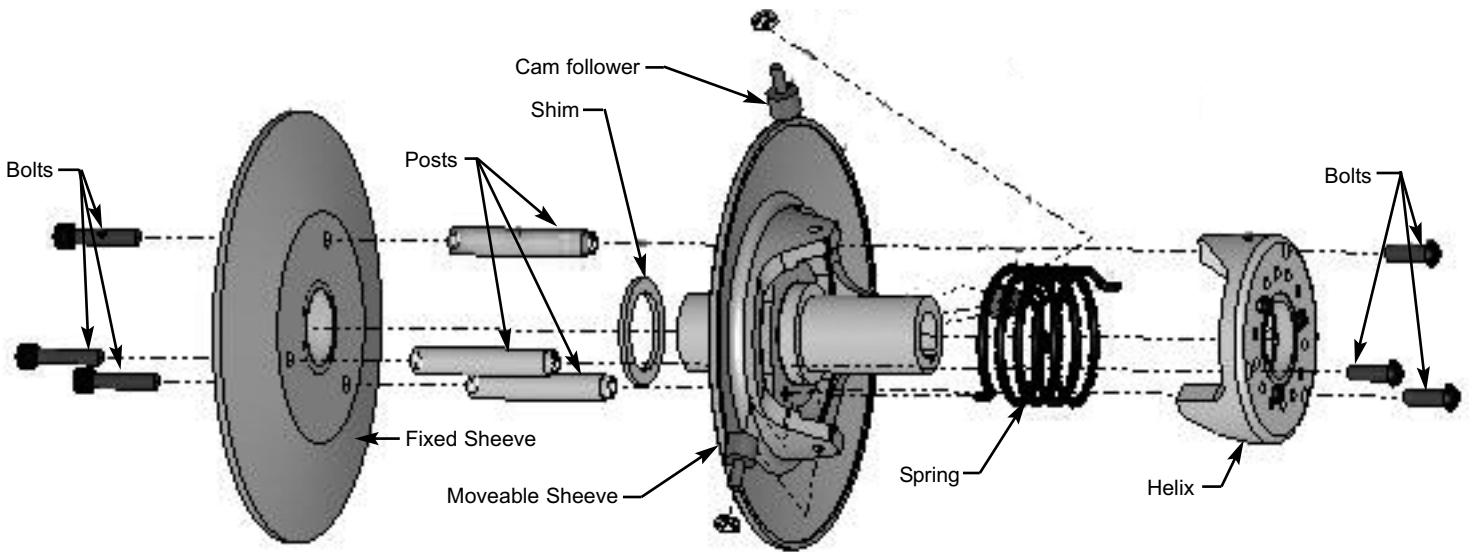

Figure 1--Reverse Driven

## **Routine Cleaning:**

(to be done at the beginning/end of each race day)

1. Clean sheeve
2. Engage by hand to check free movement

## **Race Cleaning:**

(to be done after every 4 races)

1. On the reverse driven models (figure 1), check tightness of bolts from helix to post as well as from movable to post. For the standard driven, check the snap ring for signs of fatigue.

## **Yearly Maintenance:**

(to be done once a year)

1. Complete tear down and cleaning
  - a. clean bushing, movable sheeve, helix, and fixed post
2. Be sure the roller bearings (cam follower) are clean and free rolling
3. Replace Spring
4. Re-assemble driven clutch

*Engineering performance parts for over a decade.*



**Order Line 1-800-557-5430 • Tech Line 1-970-336-5930 • [www.jracecar.com](http://www.jracecar.com)**